

Precast Concrete Freezeproof Waterers

the worry-free choice for watering livestock

The durability of precast concrete waterers provides clean water, safeguards natural water supply, and reduces the risk of contamination. Our steel-reinforced precast concrete will provide many years of service without decay, rot or rust.

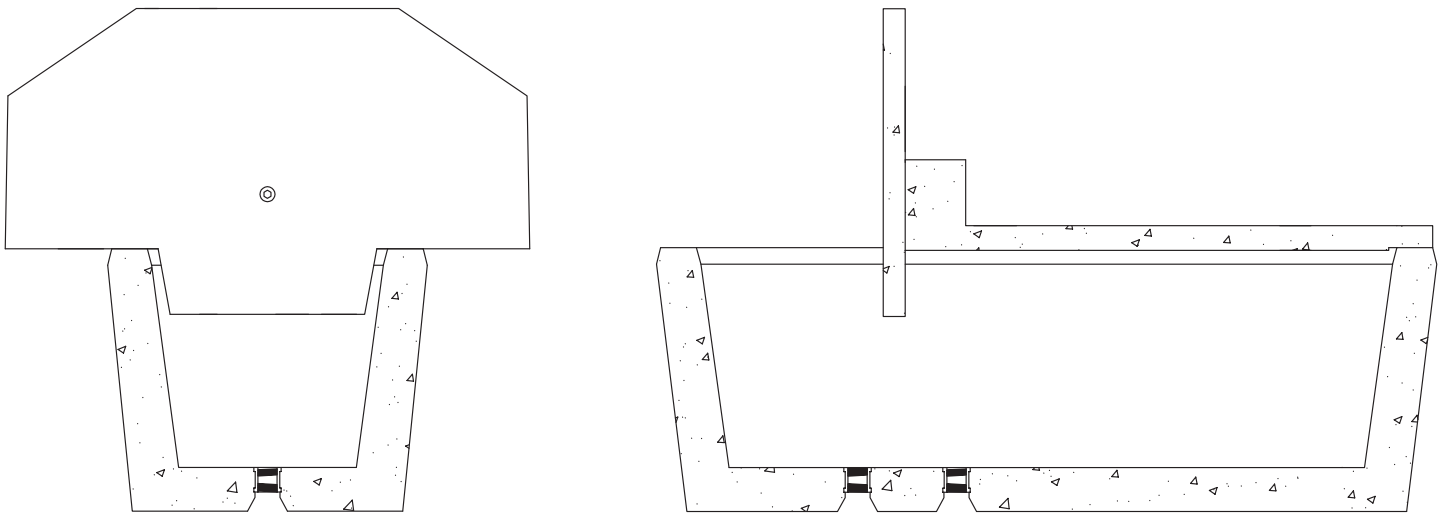

- > Ice free water supply year round
Energy efficient design provides up to 100 gallons of ice free water with little maintenance.
- > Operates without electricity
Unique design utilizes the earth's warmth to operate without electricity.
- > Preserves ponds and other natural water supplies
Prevents the risk of pond contamination and disease, and only requires six gallons of water per hour of circulation.
- > Two styles available
Pressure or spring with 1½" brass pipe coupling.

DATASHEET

FREEZEPROOF WATERERS the worry-free choice for watering livestock

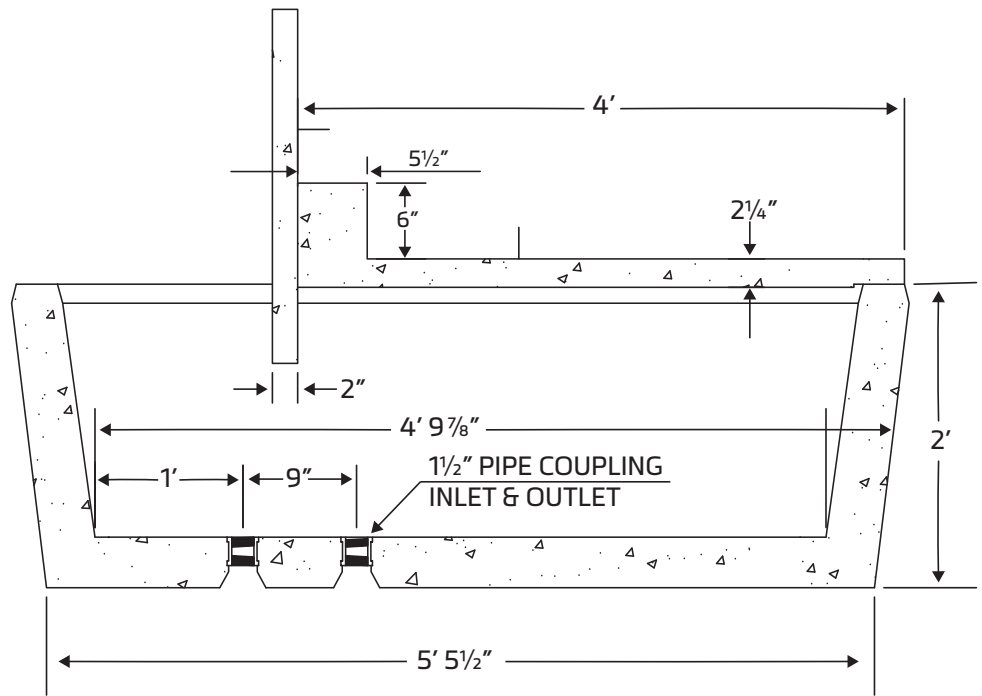
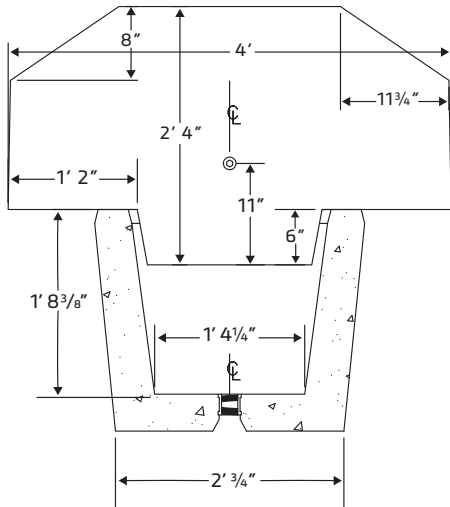

Specifications

Height	24"
Length	6'
Width	30"
Weight	2200 lb
Tapered sidewall thickness	4"
Bottom thickness	4"
Steel reinforcing	85' of 1/2" steel reinforcing rod
Drain and outlet	1 1/2" standard pipe

Notes:

- > Baffle and lid can be removed for installation.
- > Can be moved with 3/4-ton truck.
- > Installation accomplished using most front end loaders.