



## 400-Gallon Waterer

With easy delivery and installation our 100-gallon waterer is the long-lasting choice for livestock water supplies.



- **Delivered fast and made to last**  
Easy installation includes minimal site preparation and simple pipe construction.
- **Durable construction and design will never rot or rust**  
Circular design resists cracking and eliminates stress points.
- **Available for same day use**  
Durable, steel-reinforced precast provides many years without decay or rot.
- **Large 400-gallon capacity**  
Features smooth, rounded corners and edges.
- **Accepted by the soil conservation service**  
Allows livestock to water with minimal effort.
- **Great for the environment and livestock**  
Provides clean water, safeguards natural water supply, and reduces risk of contamination. The circular shape and smooth contoured edges protect livestock from injury.

### Specifications

Weight	4,500 pounds
Height	30"
Diameter	6'-6"
Steel reinforcing	120' of ½" steel reinforcing rod
Wall thickness	4" at top, 8" at bottom (tapered to minimize freeze damage)
Bottom thickness	4"
Inlet and outlet	1¼ or 1½" cast in place galvanized couplings with brass fittings (other sizes available for extra cost)
SGS approved	Approved by SGS in OH, WV, and PA

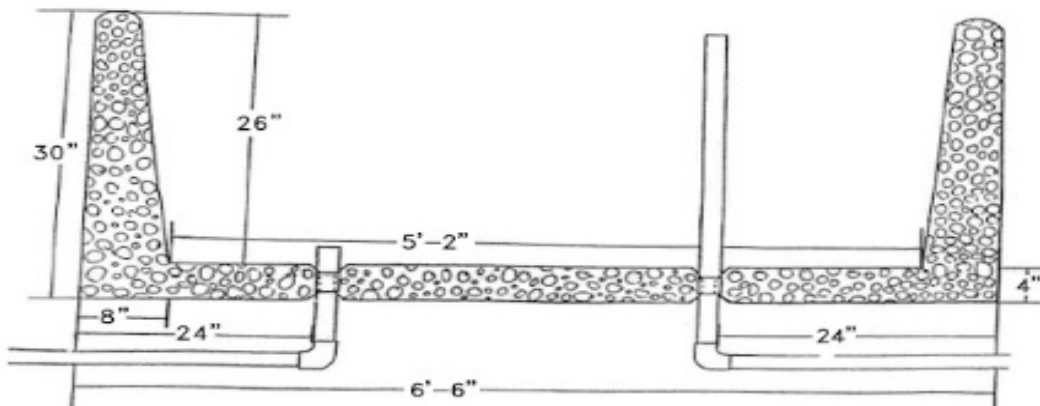

## Installation Procedures

---

1. Excavate and level an area 7½' in diameter. Depth of excavation can be adjusted to produce desired height of finished installation. Dig a 10"-12" wide trench across the center of the excavation to the depth you want the lines buried (normally 12-18").
2. Set the tank on concrete blocks or other blocking material with the inlet and outlet lined up over the trench. Attach inlet and overflow lines using a nipple to come out of the bottom of the tank to desired depth. After lines are attached, raise tank, remove blocking, and set the tank down. Make sure the lines are lowered into the trench. Pack earth into the trench and place stone around the tank. If ground is rocky, it is recommended that crushed stone be placed under the tank before installation.

*Note: When using a pressure system the overflow pipe is optional.*

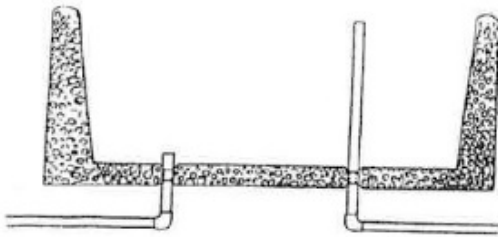

Spring Fed Installation

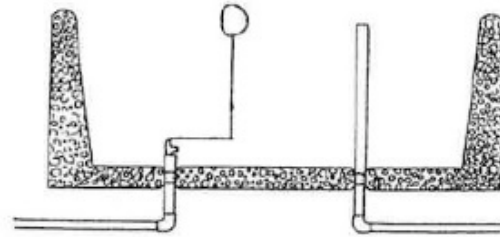

Pressure Fed Installation

## Maintenance Tips

---

- **Pressure Relief Devices**

As water freezes, it expands with tremendous force against the sides of the tank. In order to relieve this pressure, a compressive material should be introduced into the water in the winter to absorb this pressure. Some materials we have seen used successfully include: (1) a tire set on end protruding through the surface of the water and held in place by a post laid across the top of the tank; or (2) a plastic milk jug painted black on the inside and weighted with a handful of gravel. Fence posts are sometimes used but become less effective when water-logged.

- **Algae**

Many methods have been used for keeping tanks free of algae, but the best method we have found is to put in a couple of small catfish.

## Limited Warranty

---

The 400-gallon waterer is warranted to be manufactured according to specifications submitted to and approved by State Conservation Engineer, Soil Conservation Service, states of West Virginia and Ohio. The waterer is produced of 5000 psi compressive strength concrete and reinforced with #4 (½" diameter) 60 grade reinforcing bar. It is warranted to be structurally sound and will not deteriorate, crack, leak or be broken by livestock. This warranty will continue in force for a period of five (5) years from the date of installation.

The warranty does not apply if the tank has been moved from initial installation site, damaged by machinery, blasting or Acts of God. The warranty does not apply if the owner allows water in the tank to freeze over the entire top surface. Although the tapered design, smooth walls and heavy reinforcing are intended to minimize the effect of freezing, the tremendous pressures exerted when water freezes can fracture structures many

times the thickness of this waterer Contact your Soil Conservation Service or CXT® for suggestions of how to keep an unfrozen portion on the surface or how to keep pressure relief structures in the tank during the winter months. If you cannot keep a surface opening for livestock to drink, the tank has no utility as a waterer and should be drained. It is suggested that all tanks controlled by float valve or other device where water does not flow through the tank continuously be drained.

If a leak occurs which is a result of a structural defect, inferior concrete or other condition due to manufacturing, CXT will, at its option, repair or replace the waterer at our expense excluding freight and installation.