



MODULAR CONCRETE STORMWATER MANAGEMENT



RETENTION ▾

DETENTION ▾

HARVESTING ▾

INFILTRATION ▾

ENVIROKEEPER®

STORMWATER MANAGEMENT SYSTEM

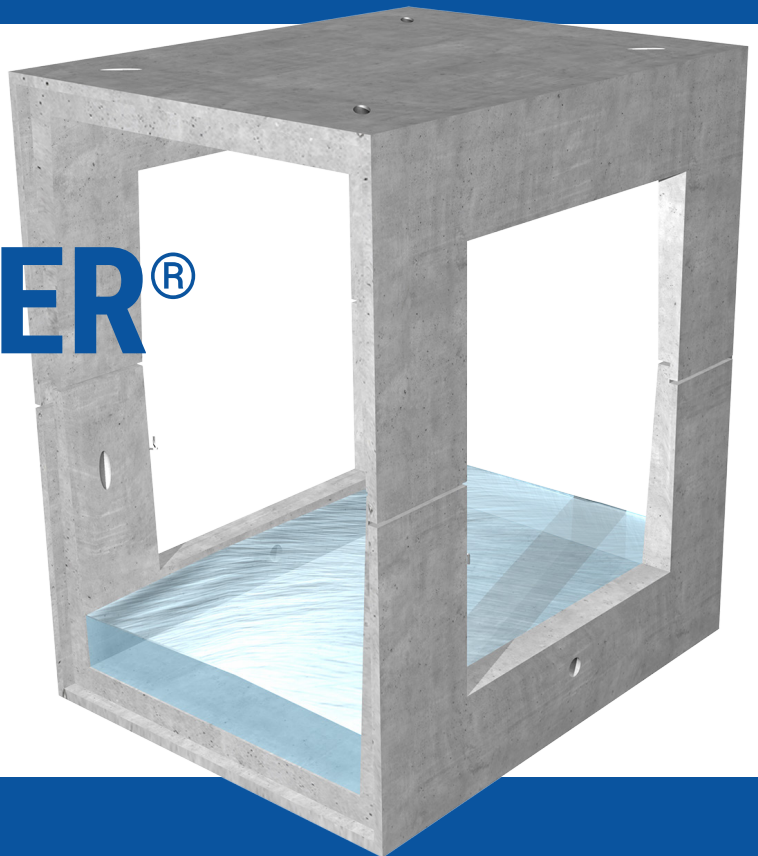

THE MODULE

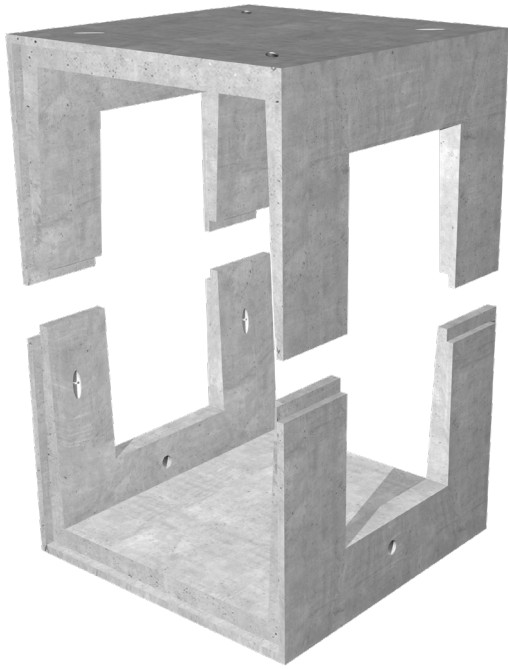

"The Envirokeeper® difference is the module and system components."

1 MODULE 4 SOLUTIONS

RETENTION • DETENTION • INFILTRATION • HARVESTING

THE SYSTEM

Envirokeeper® is a modular precast, reinforced concrete stormwater management system designed and engineered for use across multiple stormwater applications including retention, detention, infiltration, harvesting.

LOADING CONDITIONS

- Produced in a controlled environment.
- Conform to applicable ASTM's C890 & C913
- Designed to meet AASHTO HL-93/HS-20 live load ratings & variable earth cover.

THE MODULE

The Envirokeeper® module is designed to provide flexibility in application and size. The same module can be used to create endless system configurations. Module walls can be open or closed as required to close off a system or control water flow through a system.

MODULE DIMENSIONS

- Standard Module interior width – 10'-0"
- Variable Half Module interior heights – 10'-0" maximum
- Variable Full Module interior heights – 14'-0" maximum
- Slab/Footing dimensions vary based on design

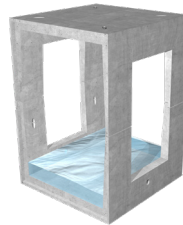

FULL MODULE

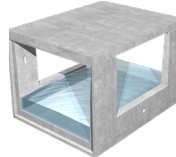

HALF MODULE W/SLAB

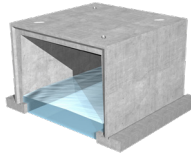

HALF MODULE W/FOOTINGS

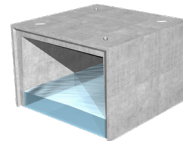

HALF MODULE

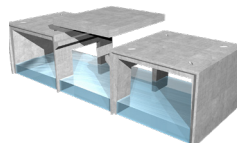

MODULE W/SPAN SLAB

RETENTION

RETENTION APPLICATIONS

Envirokeeper® stormwater retention systems provide low impact, cost-effective solutions for applications where the flow of stormwater needs to be collected and retained.

Stormwater retention is used to control and limit the amount of stormwater allowed to enter a storm drain system during a storm event by diverting and collecting large amounts of water before it can enter the drainage system.

Retention systems are often used in conjunction with water harvesting and re-use applications.

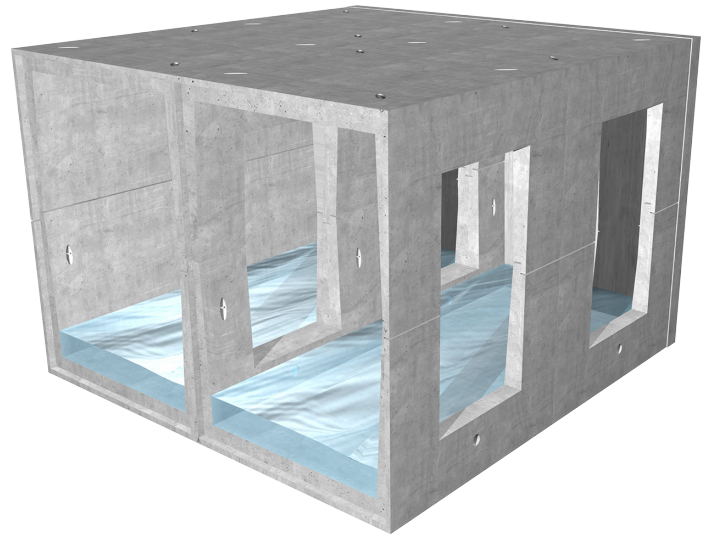

DETENTION

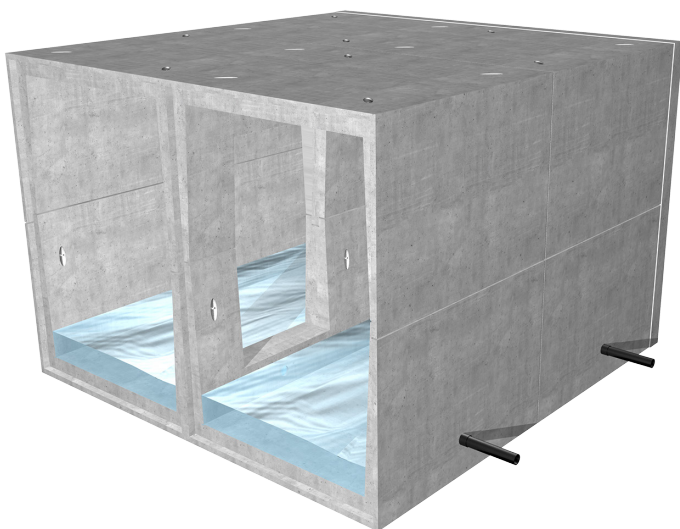

DETENTION APPLICATIONS

Envirokeeper® detention systems provide stormwater management detention solutions for applications where the flow of stormwater needs to be controlled by temporarily detaining it, and allowing it to be discharged at a controlled rate.

Detention applications help prevent drainage system overflows by collecting large amounts of water during a storm event, then regulating the amount of stormwater allowed to enter a storm drain system over time.

Treatment technology can be used with detention applications to treat contaminated stormwater, and also to collect and remove debris from the stormwater runoff.

HARVESTING

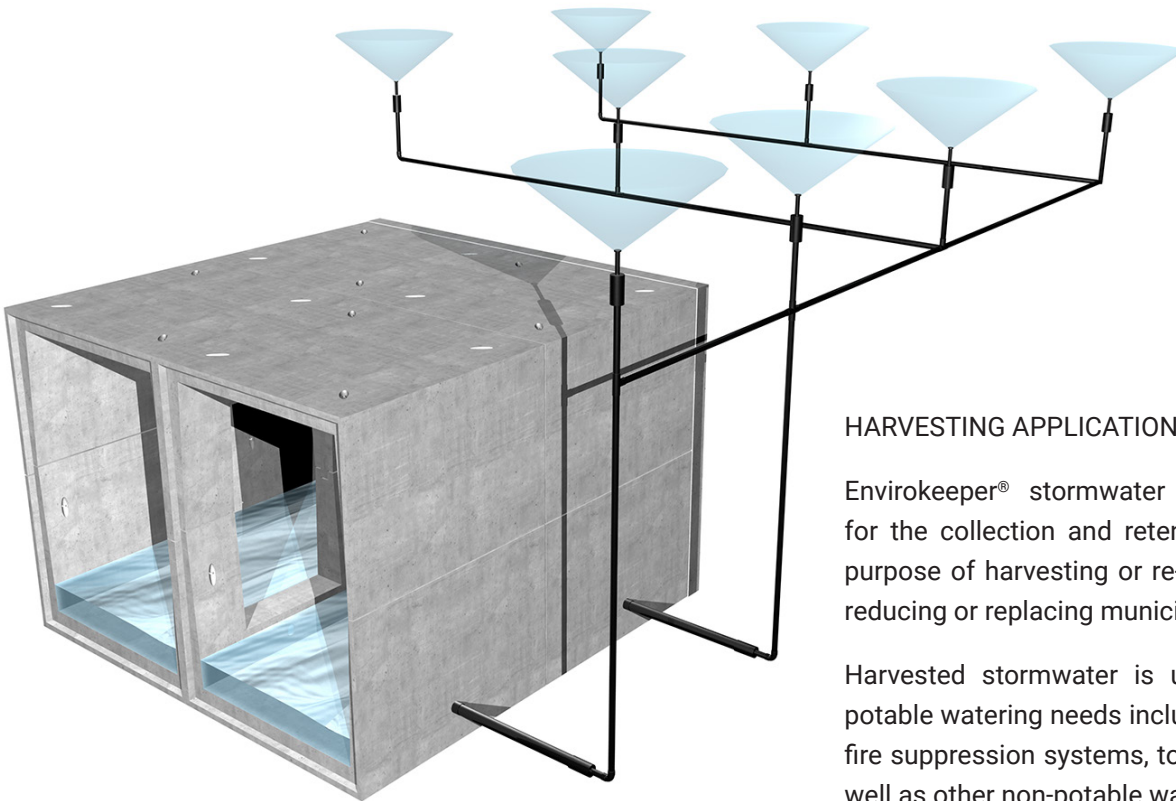

HARVESTING APPLICATIONS

Envirokeeper® stormwater harvesting systems allow for the collection and retention of stormwater for the purpose of harvesting or re-using the stormwater while reducing or replacing municipal potable water.

Harvested stormwater is used for a variety of non-potable watering needs including, landscaping irrigation, fire suppression systems, toilet flushing, car washes, as well as other non-potable water needs.



Landscape Irrigation



Groundwater Recharge



Golf Course Irrigation



Industrial Cooling



Fire Suppression



Fleet / Vehicle Washing

Typical Module Section

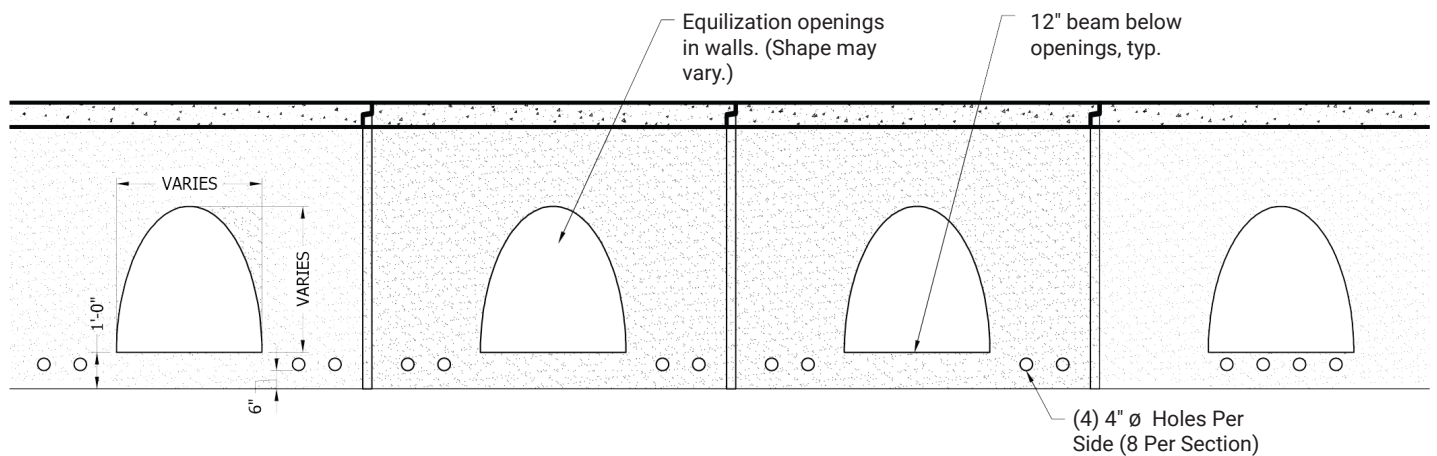

INFILTRATION

INFILTRATION APPLICATIONS

Envirokeeper® stormwater management modules are the perfect solution for applications that require stormwater to be collected and allowed to infiltrate back into the soil for groundwater recharge.

Inverted modules with footings can be designed and engineered for traffic rated applications. The open bottom systems can also incorporate a variety of infiltration media as required.

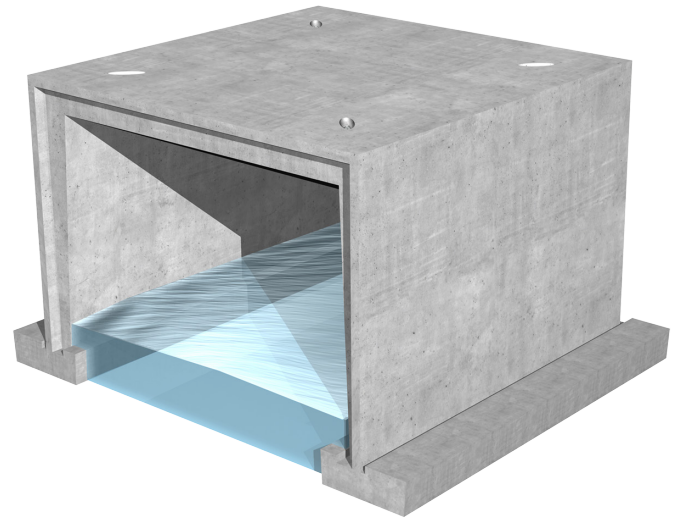

Standard Infiltration Components

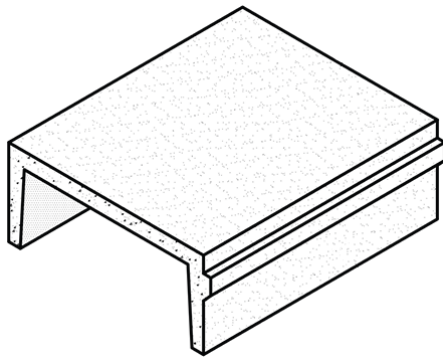

Half Module

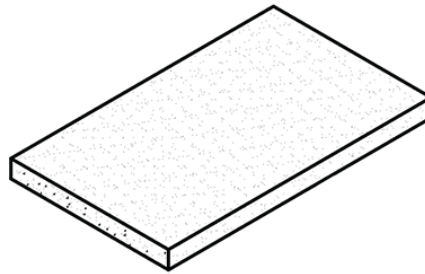

Slab

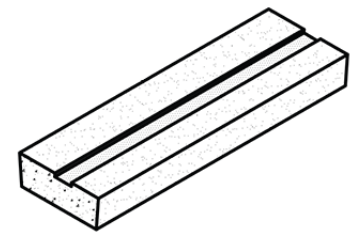

Footing

Half Module / 3-Sided Culvert

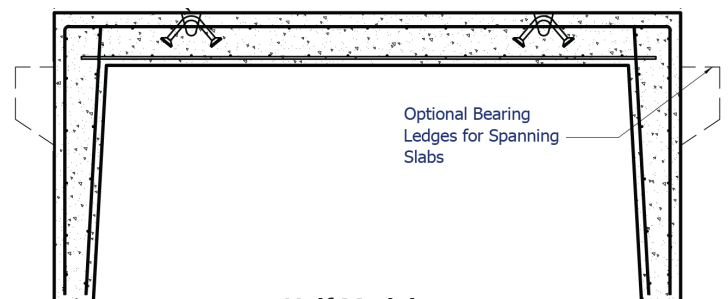
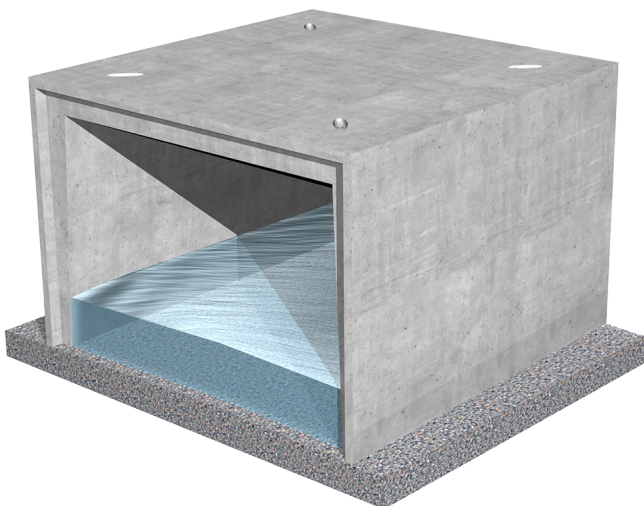

Half Module

STANDARD MODULE CONFIGURATIONS

Envirokeeper® stormwater modules can be designed and assembled in a variety of system configurations to provide site-specific stormwater management solutions. Whether your site calls for a full module enclosed retention system, or a half module infiltration system, our team of design and engineering experts can ensure you get the stormwater management solution your site requires with the performance you need.

Half Module

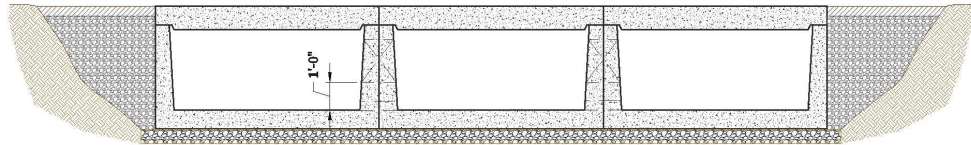

**Half Module
Cover Slab**

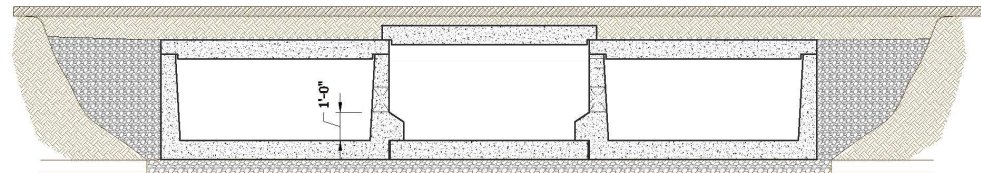

**Half Module
Ledge Slab
w/Footings**

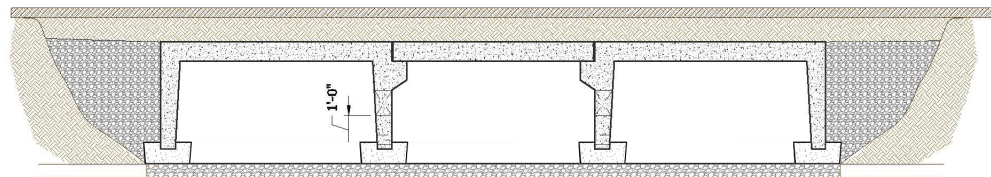

**Half Module
Infiltration**

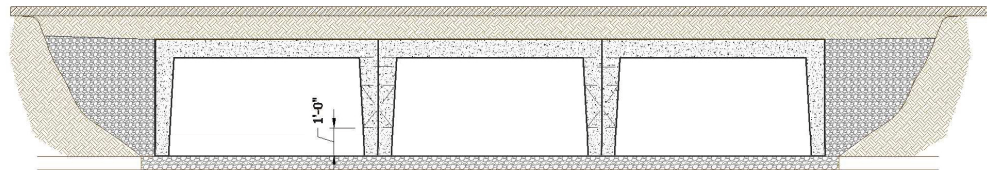

**Full Module
Span Slab**

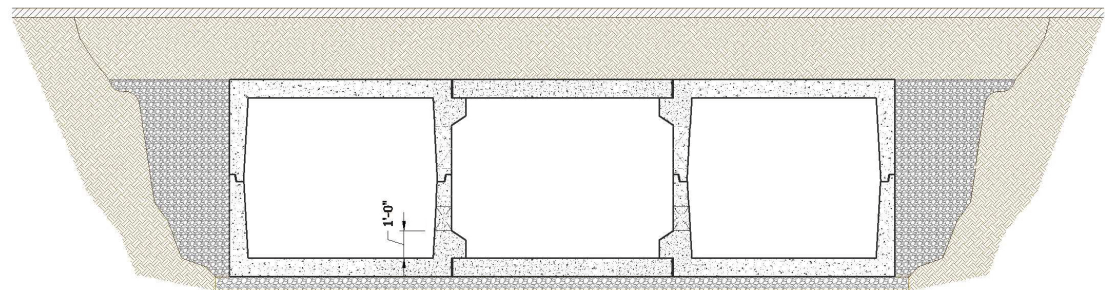

Full Module

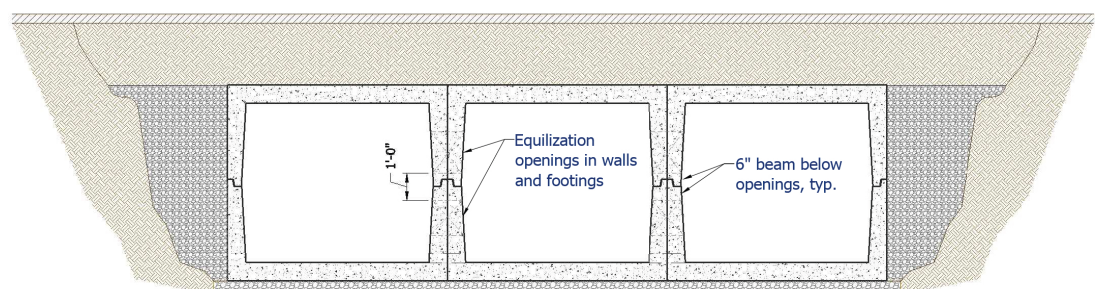

STANDARD MODULE OPTIONS

Envirokeeper® system modules are designed and engineered to be used as stormwater management solutions in a variety of jobsite applications. From low-profile half modules for storage or infiltration, to full height modules offering increased storage capacity, Envirokeeper modular solutions offer the design and engineering flexibility to meet any site specific stormwater management needs.

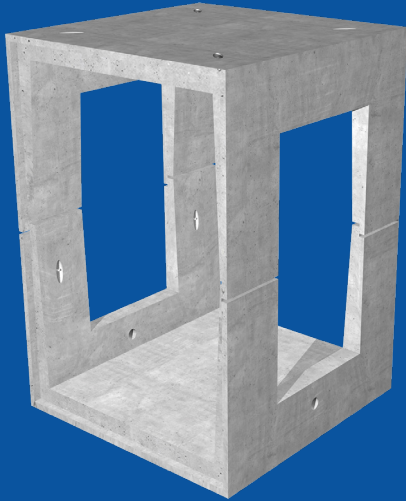

FULL MODULE

- Retention
- Detention
- Harvesting

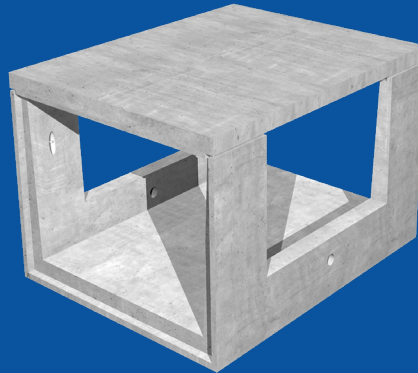

HALF MODULE

- Retention
- Detention
- Harvesting

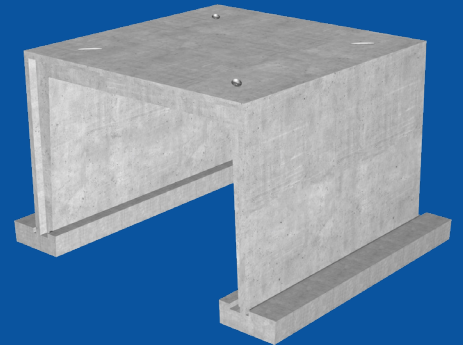

HALF MODULE /FOOTING

- Infiltration
- Conveyance

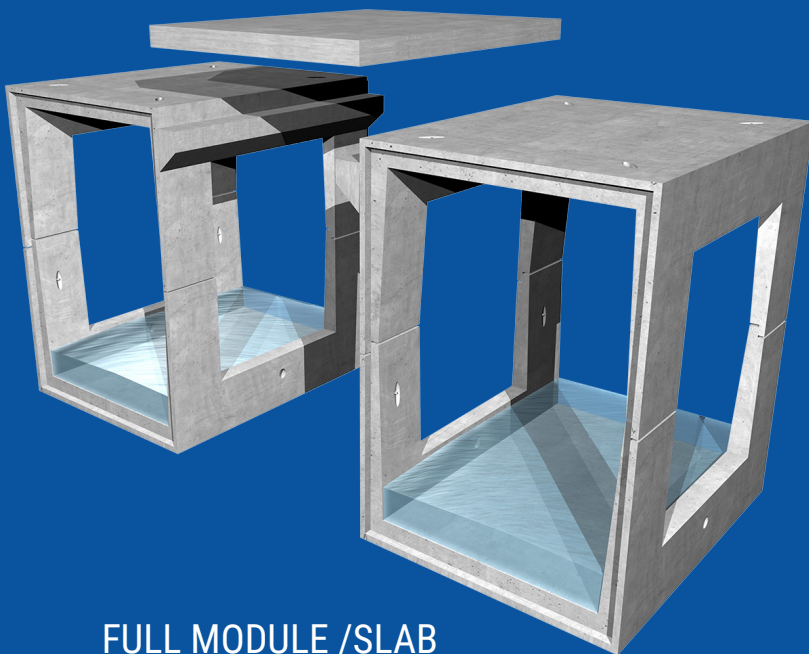

FULL MODULE /SLAB

- Retention
- Detention
- Harvesting

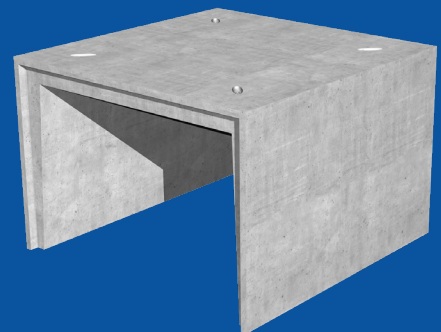

HALF MODULE

- Infiltration
- Conveyance

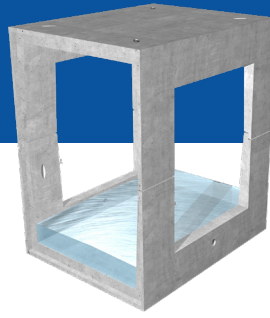

ENVIROKEEPER®

STORMWATER MANAGEMENT SYSTEM



CXT® is a leading manufacturer of precast concrete products for the agricultural, civil, communications, energy, environmental, transportation, and water/wastewater industries. From essential municipal utilities to critical transportation and energy infrastructures, we are committed to providing practical solutions engineered to keep our world moving.



CXT® is a licensee of Envirokeeper®, LLC.

© 2023 CXT, Inc.
Envirokeeper_001_1023
CXT is a licensee of ENVIROKEEPER, LLC.