



Delivering L.B. Foster innovation

PRECAST CONCRETE BUILDINGS

www.cxtinc.com

800.696.5766



CXT® concrete restroom, concession, shower, utility, and multipurpose buildings are durable, versatile, strong, and can be easily customized to meet the specific needs of each project.

CXT restroom, shower, concession, utility, and multipurpose buildings are delivered to your site ready to use and require no construction, concrete blocks or tilt-up panels that increase installation time. Our structures are manufactured with high-strength precast concrete floors, walls, and roofs and are aesthetically designed in multiple floor plans, colors, and textures. Our vandal-resistant engineering minimizes abusive wear and maximizes our structures' service life under extreme weather conditions.

Our buildings meet all local and state building codes and A.D.A. specifications.

CXT concrete buildings are manufactured at three facilities in the United States: Nampa, Idaho; Hillsboro, Texas; and Williamstown, West Virginia. All three plants are ISO 9001:2015 certified, which means that they meet the highest standards of quality and safety.

SIMPLE TO INSTALL

- Minimal site preparation required.
- Pre-plumbed and wired for efficient installation.

READY TO USE

- Prefabricated and delivered complete and ready to use.
- Can typically be in use on the day of installation.

EASY TO MAINTAIN

- Interiors resist abusive wear.
- Quickly cleaned with warm soapy water and a brush.



CXT steel-reinforced concrete buildings are engineered to maintain their aesthetics and withstand extreme conditions caused by snow, wind, water, and zone 4 seismic loads.

Vandal-resistant components help minimize abusive wear and maximize the structures' service life.

Construction specifications:

- 5" thick steel-reinforced concrete roof
- #3 reinforcing perimeter bar
- 4x4xW8xW8 welded wire fabric
- 3/8" studded steel weld plates
- 5000 PSI concrete
- 4" thick steel-reinforced concrete walls
- 5" thick steel-reinforced concrete floor



Multiuser Restrooms

Arapahoe - 20' x 26'

Four Family Assist Flush Restrooms

Fixtures:

- 4 ADA toilets
- 4 sinks
- ADA grab bars
- Interior and exterior lights

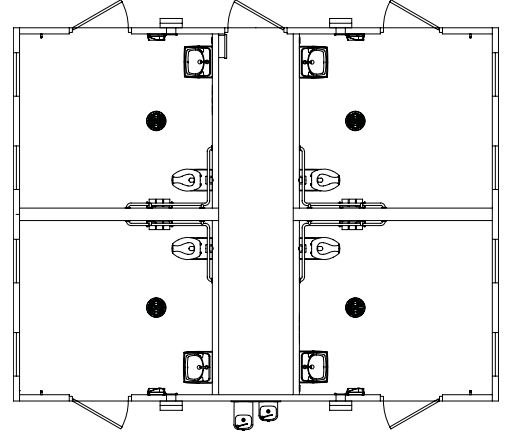

Montrose - 21' x 26'

Two Multiuser Fully Accessible Flush Restrooms

Fixtures:

- 3 toilets (2 ADA)
- 1 urinal
- 2 sinks
- ADA grab bars
- Interior and exterior lights

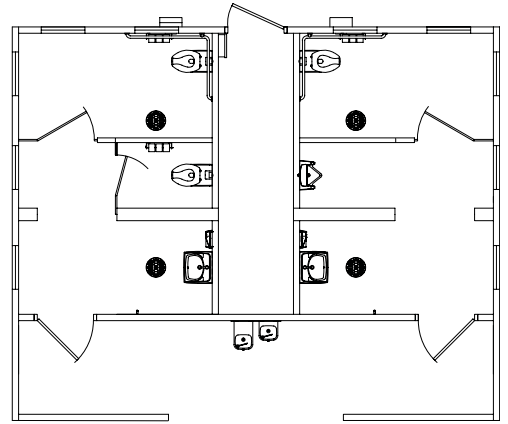

Taos - 20' x 26'

Two Multiuser Fully Accessible Flush Restrooms

Fixtures:

- 6 total, any combination of toilets and urinals (2 ADA)
- 4 sinks
- ADA grab bars
- Interior and exterior lights

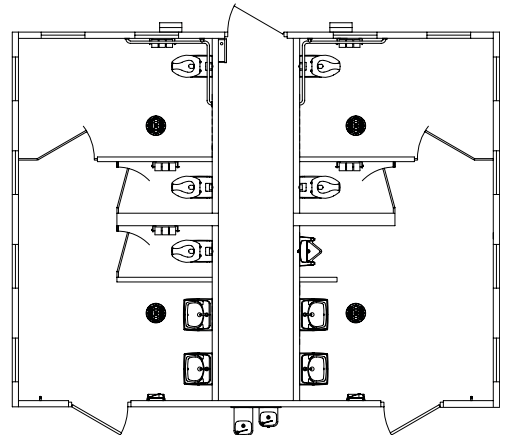

Kodiak - 10' 6" x 23' 8"

Two Multiuser Fully Accessible Flush Restrooms

Fixtures:

- 3 toilets (2 ADA)
- 1 urinal
- 2 sinks
- ADA grab bars
- Interior and exterior lights

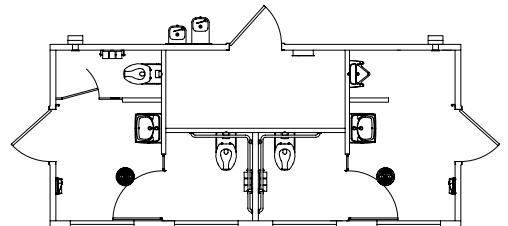

Dakota - 11' x 26'

Two Multiuser Fully Accessible Flush Restrooms

Fixtures:

- 3 ADA toilets
- 1 urinal
- 2 sinks
- ADA grab bars
- Interior and exterior lights

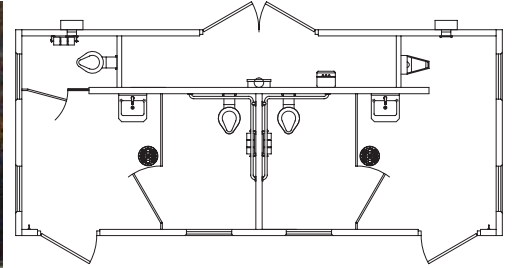

DK-4 - 11' x 26'

Four Single User Fully Accessible Flush Restrooms

Fixtures:

- 4 toilets (3 ADA)
- 4 sinks
- ADA grab bars
- Interior and exterior lights

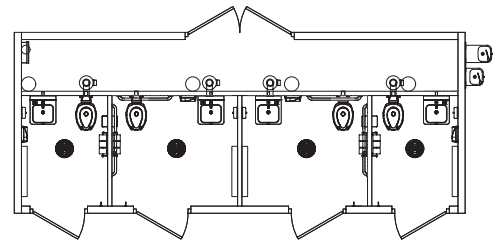

Concession Buildings

Malibu - 31' x 26'

Multiuser Restrooms with Concession

Fixtures:

- 4 total, any combination of toilets and urinals (2 ADA)
- 2 sinks
- ADA grab bars
- 6' roll-up concession door
- 3-compartment stainless steel sink
- Interior and exterior lights

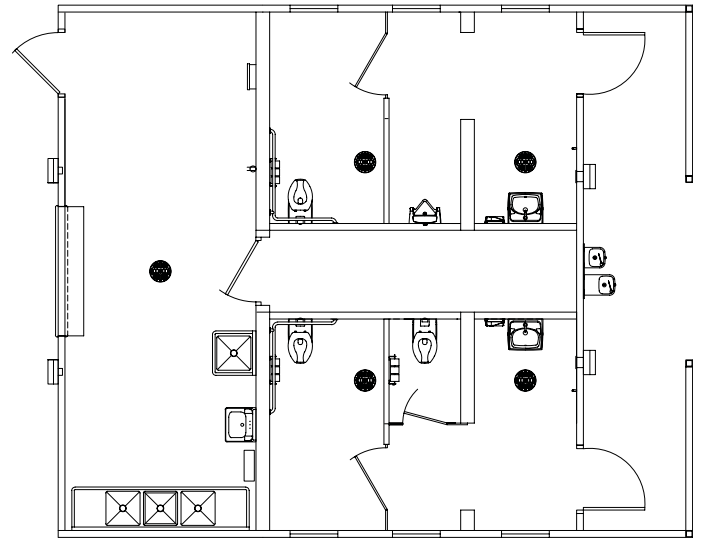

Pomona - 30' x 26'

Multiuser Restrooms with Concession

Fixtures:

- 6 total, any combination of toilets and urinals (2 ADA)
- 4 sinks
- ADA grab bars
- 6' roll-up concession door
- 3-compartment stainless steel sink
- Interior and exterior lights

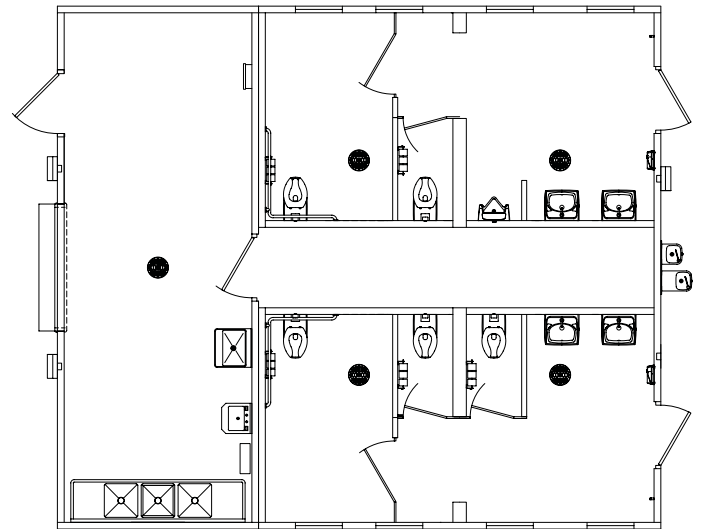

Keystone - 21' x 26'

Multiuser Restrooms with Concession

Fixtures:

- 3 toilets (2 ADA)
- 1 urinal
- 2 sinks
- ADA grab bars
- 6' roll-up concession door
- 3-compartment stainless steel sink
- Interior and exterior lights

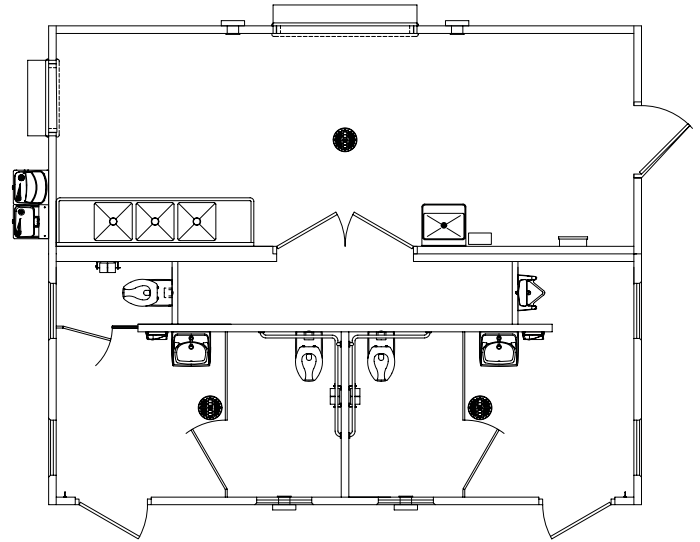

Fontana - 10' x 26'

Concession or Storage Building

Fixtures:

- 6' roll-up concession door or storage door
- 3-compartment stainless steel sink
- Interior and exterior lights

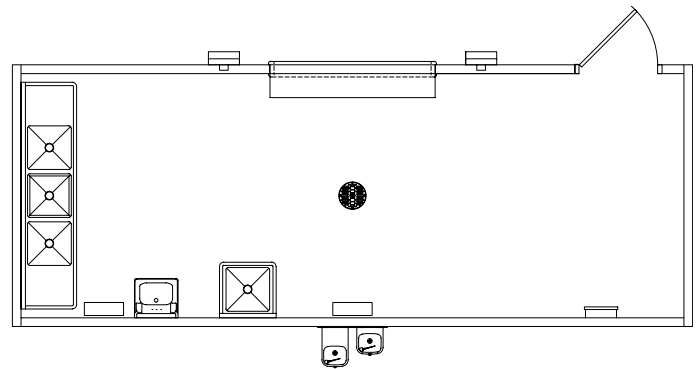

Shower Buildings

Cheyenne - 26' x 30'

Two Multiuser Fully Accessible Restrooms with Four Separate Shower Rooms

Fixtures:

- Water heater
- 6 total, any combination of toilets and urinals (2 ADA)
- 4 sinks
- ADA grab bars
- Interior and exterior lights

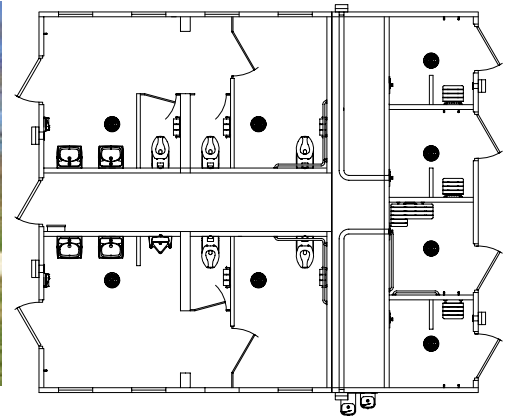

Navajo - 20' x 26'

Four Family Assist Flush Restrooms with Showers

Fixtures:

- Water heater
- 4 ADA toilets
- 4 sinks
- ADA grab bars
- Interior and exterior lights

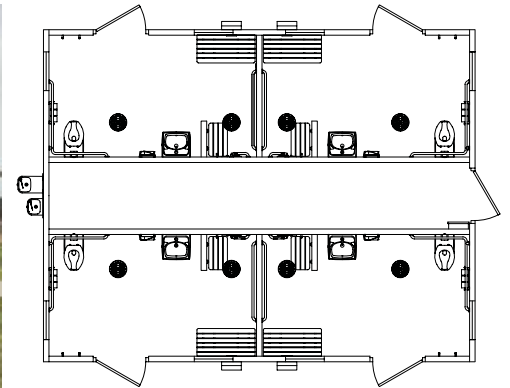

Rainier - 10'6" x 23'

Two Fully Accessible Restrooms with Showers

Fixtures:

- Water heater
- 2 ADA toilets
- 2 sinks
- ADA grab bars
- Interior and exterior lights

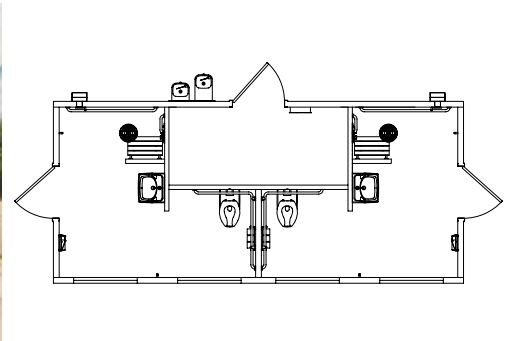

Pioneer - 10'6" x 12'

Single User Fully Accessible Restroom with Shower

Fixtures:

- Water heater
- 1 ADA toilet
- 1 sink
- ADA grab bars
- Interior and exterior lights

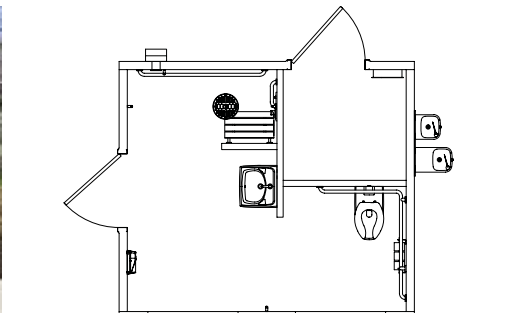

Tougher Than Kits, Block or Steel



Single User Restrooms

Two Single User Restrooms

Fixtures:

- 2 ADA toilets
- 2 sinks
- ADA grab bars
- Interior and exterior lights

Cortez - 10' 3" x 17'

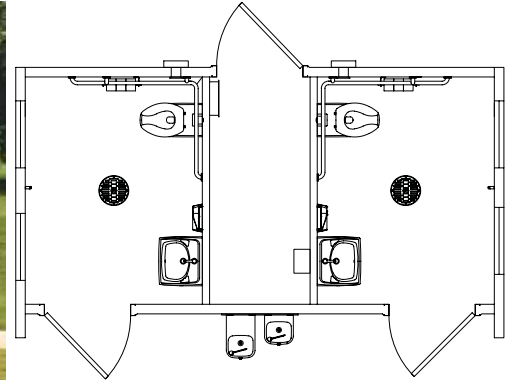

Denali - 10' 3" x 17'

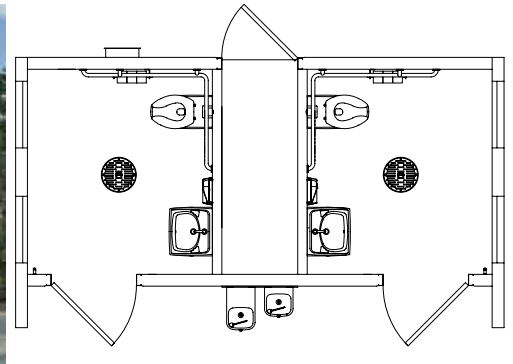

Ozark II - 10' 6" x 18' 8"

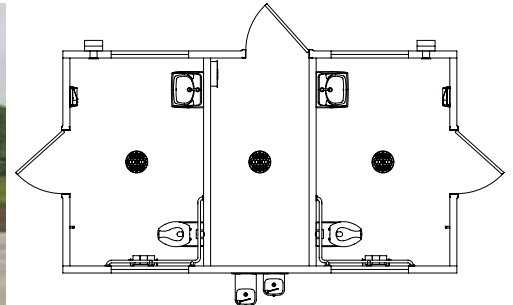

Unisex Restroom

Fixtures:

- 1 ADA toilet
- 1 sink
- ADA grab bars
- Interior and exterior lights

Ozark I - 10' 6" x 12'

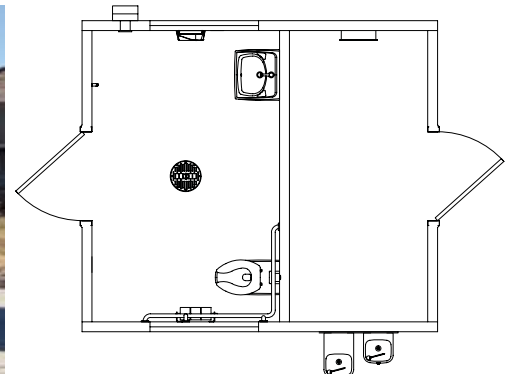

Interiors / Chase



Delivered, Installed, Ready to Use



Single Vault Restrooms

One Single User Waterless Restroom

- 1 waste clean out hatch
- 1- 1,000 gallon concrete waste vault

Fixtures:

- 1 ADA toilet riser with seat
- ADA grab bars

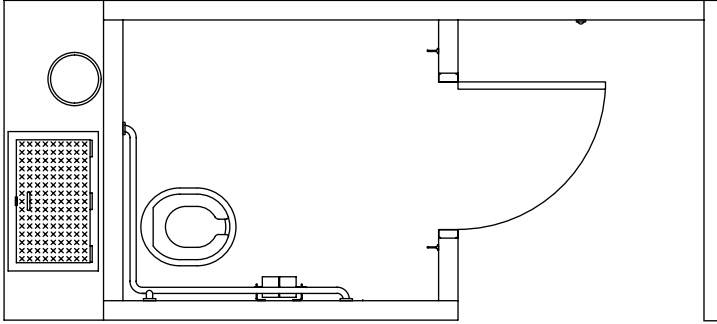

Standard Single Vault Floor Plan (right hand)

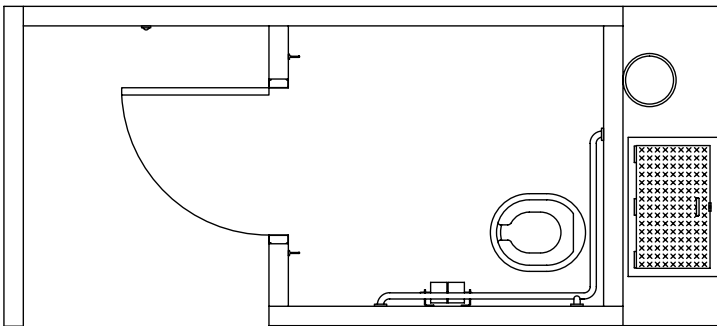

Standard Single Vault Floor Plan (left hand)



Cascadian



Gunnison



Rocky Mountain



Sweet Smelling Technology

- Designed and placed to ensure an unobstructed airflow over the top of the vent stack for passive ventilation.
- The location of the wall vent and orientation of the building takes advantage of the unobstructed airflow.
- The positive continual air flow carries the vault air out through the vent pipe keeping the building odor-free.



Double Vault Restrooms

Two Single User Waterless Restrooms

- 2 waste clean out hatches
- 2- 1,000 gallon concrete waste vaults

Fixtures:

- 2 ADA toilet risers with seat
- ADA grab bars

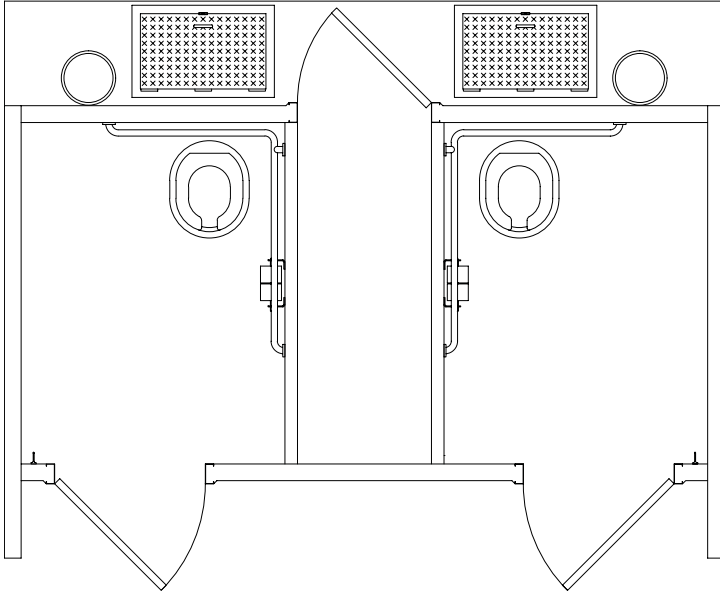

Standard Double Vault Floor Plan



Double Cascadian



Double Rocky Mountain



Tioga



Vault Installation

- Installed below ground level with vault dimensions that match the perimeter of the building to provide a stable structure that supports the full weight of the building.
- Each vault holds up to 1,000 gallons of waste (approximately 15,000 uses).
- Sloped so that waste will drain to the clean out end.
- Lined with a black polyethylene liner that is cast into the side walls of the concrete vault using dovetail embeds.



Custom Vault Designs

Wasatch

Three Single User Waterless Restrooms

- 3 waste clean out hatches
- 3- 1,000 gallon concrete waste vaults

Fixtures:

- 3 ADA toilet risers with seat
- ADA grab bars



CXT can customize vault restrooms that will meet your project needs. Contact your regional sales representative to aid in designing a custom vault building for your project.

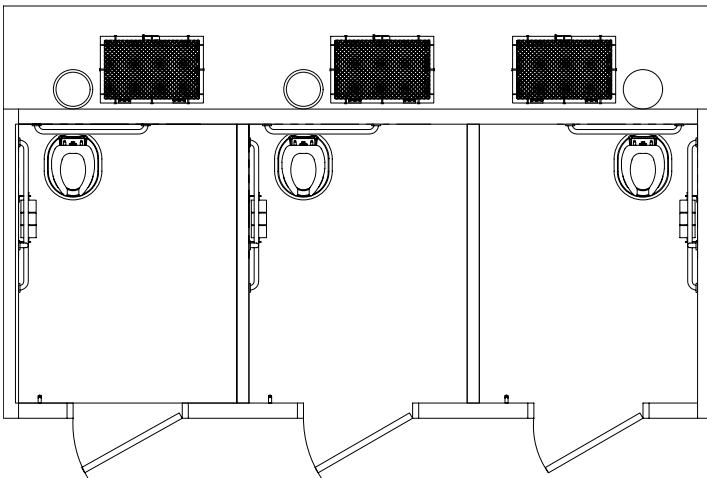

Multipurpose/Utility Buildings

- Two standard sizes:
 - » 10' 6" x up to 12'
 - » 10' 6" x 12' to 20'
- Galvanized 3068 steel door
- Wall vent



- Customizable to accommodate a variety of uses, such as:
 - » Storage
 - » Electric and communication equipment
 - » Ticket/information building
 - » Pump and utility equipment
 - » Guard house and office



Custom Buildings

CXT can customize colors, textures and other options like privacy walls, porches and awnings to match the aesthetics of the project. Other rooms such as laundry, changing, storage, and locker rooms can be added to enhance the amenities at your location.



Flush restroom with custom roof pitch



Flush restroom and fish cleaning station



Flush restroom/concession with custom roll up door



Custom screen for double vault restroom

Contact your regional sales representative to assist with designing a custom building.



Flush restroom with golf cart shelter



Tough as Mother Nature





CXT buildings can withstand extreme conditions caused by flood, snow, wind, and zone-4 seismic loads. They will not rot, rust or burn, and have a UL752 bullet resistant rating.

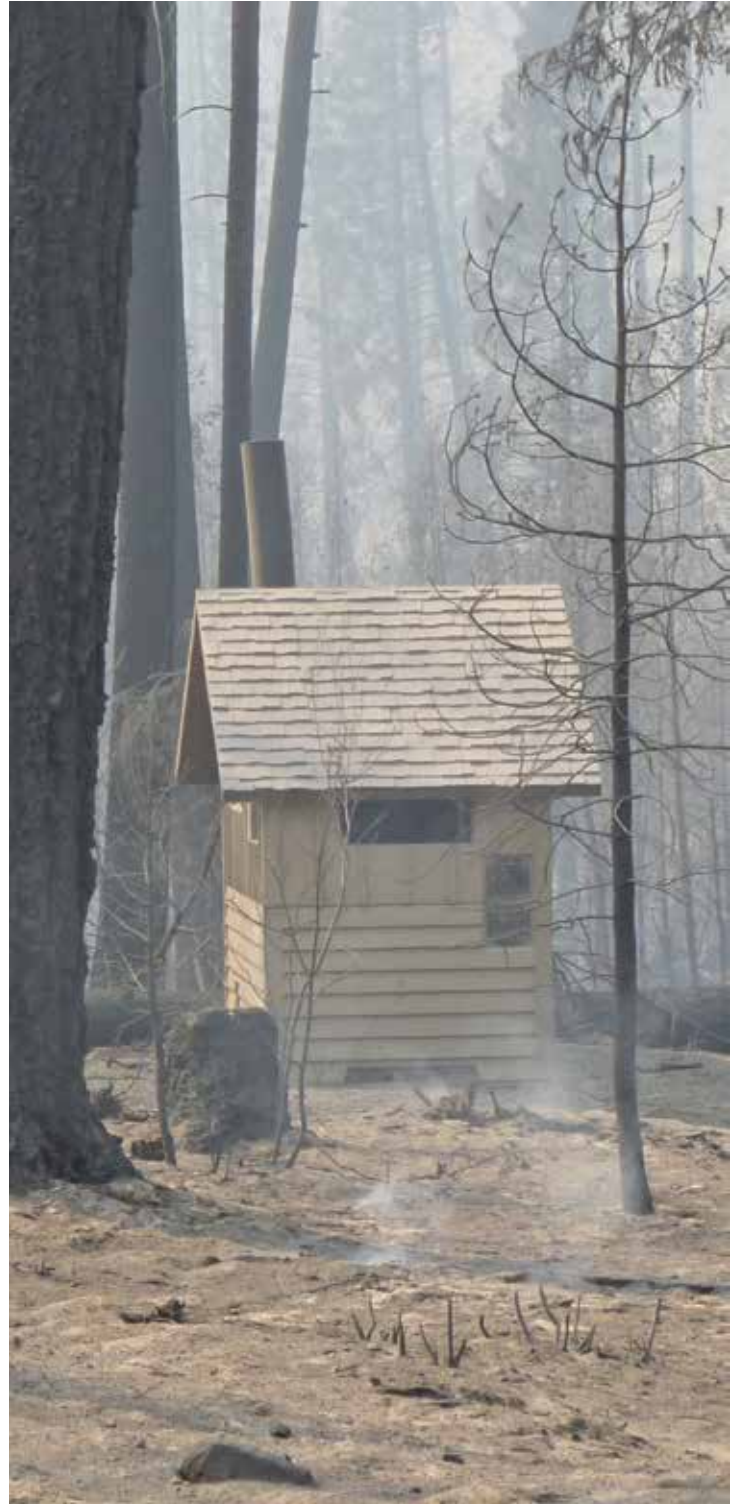

CXT buildings can be found at recreational sites, including federal, state, county, city, and private facilities in the United States and Canada.

Our buildings are precast concrete structures that are designed for durability and ease of installation. CXT buildings require minimal site preparation and can typically be in use on the day of installation. They are prefabricated and delivered complete and ready to use, including plumbing and electrical where applicable. The interiors are designed to resist abusive wear and can be cleaned quickly with warm soapy water and a brush.



Colors

Exterior



Amber Rose



Berry Mauve



Buckskin



Cappuccino
Cream



Charcoal Gray



Cocoa Milk



Evergreen



Georgia Brick



Golden Beige



Granite Rock



Hunter Green

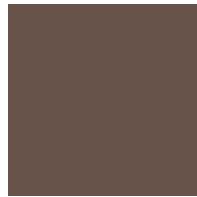

Java Brown



Liberty Tan



Malibu Taupe



Mocha
Caramel



Natural Honey

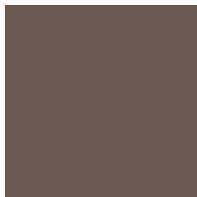

Nuss Brown



Oatmeal Buff



Pueblo Gold



Raven Black



Rich Earth

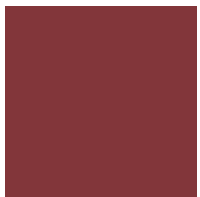

Rosewood

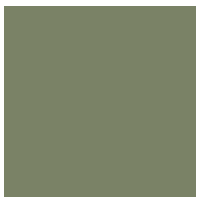

Sage Green



Salsa Red

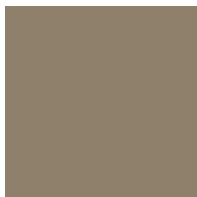

Sand Beige

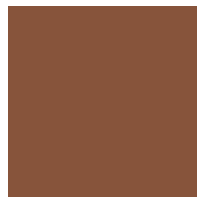

Sun Bronze



Toasted
Almond



Western
Wheat

DISCLAIMER: The color samples shown are approximations only. Job site-applied colors will vary from this color chart due to printing variances as well as the texture and porosity of the substrate. CXT® recommends applying a color sample to an inconspicuous area on the actual substrate to verify color choice.

Customers can also request specific colors by providing the paint code, paint supplier, and a description of the desired color.

Exterior Stone



Basalt



Mountain Blend



Natural Grey



Romana

Textures

Exterior Wall



Barnwood



Board & Batt



Horizontal Lap



Stucco



Split Face Block



Distressed Wood

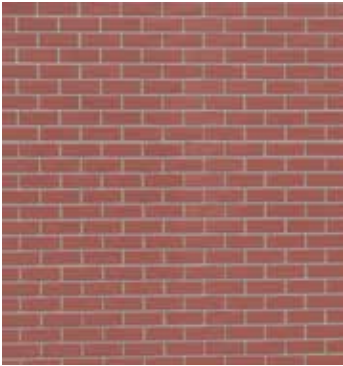

Brick



Napa Valley



River Rock



Flagstone



Stacked Rock

Roof



Cedar Shake



Ribbed Metal





www.cxtinc.com
800.696.5766
sales@lbfoster.com

606 N. Pines Road, Suite 202
Spokane Valley, WA 99206



PRECAST CONCRETE BUILDINGS

Version 7.0 [2024]